

PRODUCT FEATURES

- Premium Cubelet ice.
- Smooth ice dispense.
- No ice bridging.
- Robust and reliable.
- Sanitary self-service application.
- Easy operation - Push button; dispense ice directly in to container greatly reducing risk of contamination.
- Dispenses ice only, water only or ice and water.
- Adjustable portion-controlled dispensing.
- Due to auger system water consumption is equal to ice production.
- 2 year parts & labour on entire unit, 5 year (parts only) on compressor & air cooled condenser coil.

SHAPE OF ICE:



TECHNICAL DRAWING

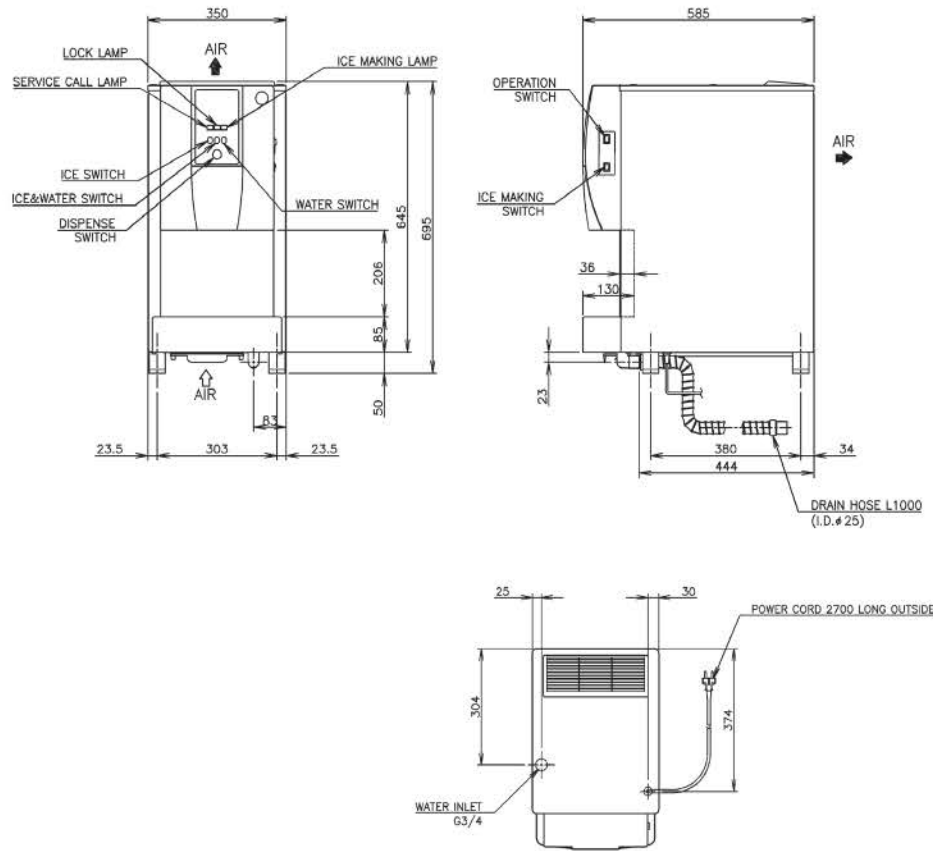

PRODUCT SPECIFICATION

Production Capacity per 24hours	Approx. 60kg @10°C Air temp; 10°C Water Approx. 50kg @ 21°C Air temp; 15°C Water Approx. 38kg @ 32°C Air temp; 21°C Water
Max Storage Capacity	Approx. 1.9kg
Dimensions	350mm (W) x 585mm (D) x 695mm (H)
Cooling	Air
Weight Net/Gross (kg)	47 / 56
AC Supply Voltage	1 PHASE 220 - 240V 50Hz /10AMP Plug
Amperage	Rated:1.5 A Starting: 9.5 A
Refrigerant Charge	R134a
Operating Conditions	Ambient Temp.: 5-40°C Water Supply Temp.: 5-35°C Water Supply Pressure: 0.07-0.8MPa Voltage Range: Rated Voltage ±6%